

System depth			
Bracket	min. D system depth	max. D system depth	t panel thickness
Alpha H 035	2 <sup>3</sup> / <sub>4</sub> " (69mm)	3 <sup>15</sup> / <sub>16</sub> " (100mm)	varies
Alpha H 050	3 <sup>1</sup> / <sub>16</sub> " (78mm)	4 <sup>9</sup> / <sub>16</sub> " (115mm)	varies
Alpha H 080	4 <sup>1</sup> / <sub>4</sub> " (108mm)	5 <sup>3</sup> / <sub>4</sub> " (145mm)	varies
Alpha H 115	5 <sup>5</sup> / <sub>8</sub> " (143mm)	7 <sup>1</sup> / <sub>8</sub> " (180mm)	varies
Alpha H 150	7" (178mm)	8 <sup>1</sup> / <sub>2</sub> " (215mm)	varies
Alpha H 185	8 <sup>3</sup> / <sub>8</sub> " (213mm)	9 <sup>7</sup> / <sub>8</sub> " (250mm)	varies
Alpha H 220	9 <sup>3</sup> / <sub>4</sub> " (248mm)	11 <sup>1</sup> / <sub>4</sub> " (285mm)	varies
Alpha H 235	10 <sup>3</sup> / <sub>8</sub> " (263mm)	11 <sup>13</sup> / <sub>16</sub> " (300mm)	varies

Legend

- |   |  |  |
|---|--|--|
| <ul style="list-style-type: none"> <li>1. Steel stud (16 GA typical)</li> <li>2. Perimeter anchor</li> <li>3. Alpha H wall bracket</li> <li>4. st/st self-drilling screw <math>\frac{3}{16} \times \frac{3}{4}</math>"</li> <li>5. st/st self-drilling screw <math>\frac{1}{4} \times 1</math>"</li> <li>6. Horizontal L-profile</li> <li>7. Vertical Z-profile</li> <li>8. Vertical Hat-profile</li> <li>9. Blind rivet</li> <li>10. Insulation</li> </ul> | <ul style="list-style-type: none"> <li>11. Panel</li> <li>12. A/V barrier</li> <li>13. Exterior wall</li> <li>14. Outer corner closure</li> <li>15. Inner corner closure</li> <li>16. Jamb closure</li> <li>17. Vertical L-profile</li> <li>18. Coping</li> <li>19. Perforated window head closure</li> <li>20. Window sill</li> </ul> | <ul style="list-style-type: none"> <li>21. Perforated base closure</li> </ul> <p>D - System depth<br/>t - Panel thickness<br/>* Ventilation will vary based on insulation depth.<br/>** Minimum ventilation requirement should be qualified by panel manufacturer.</p> |
|---|--|--|

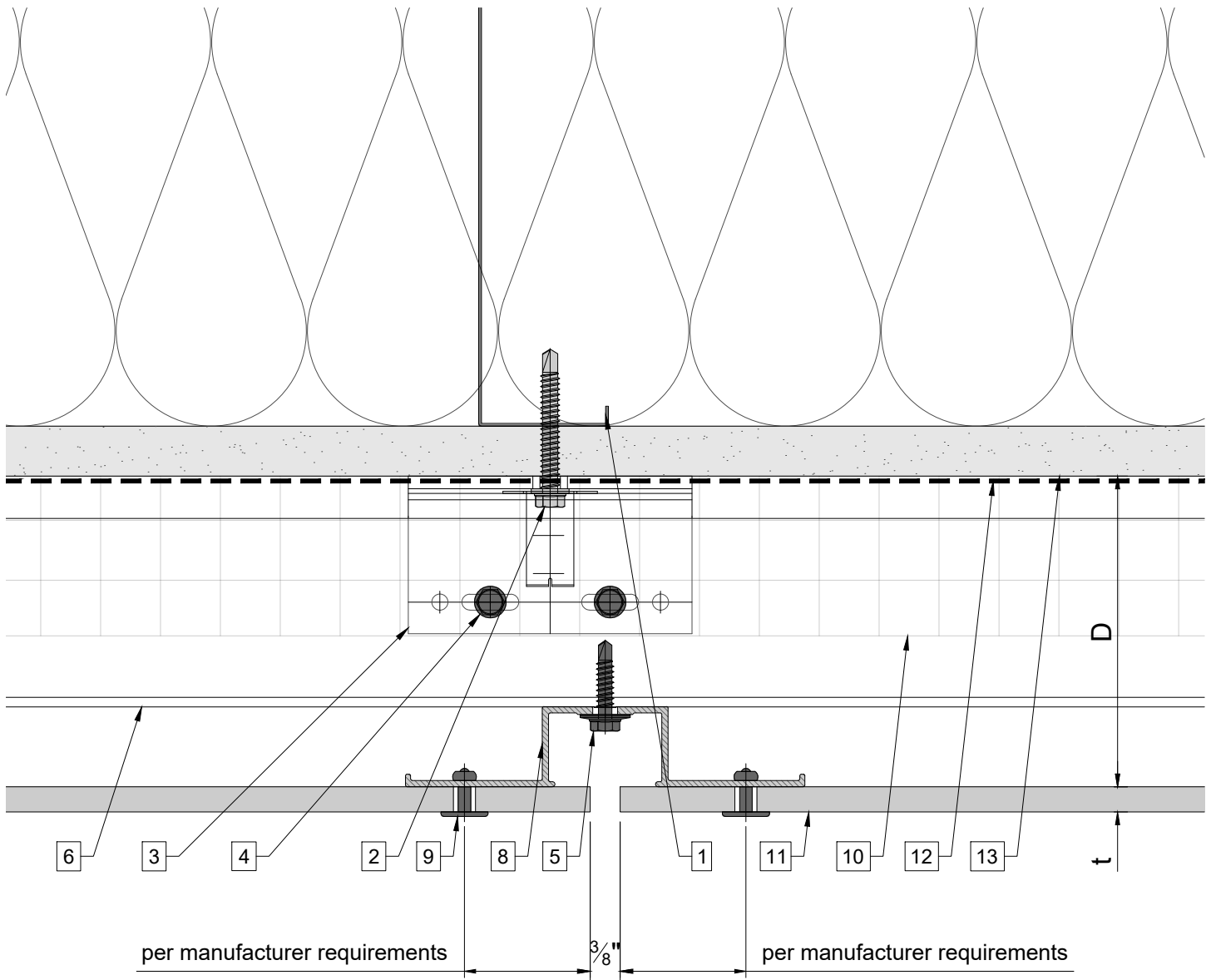

**Legend**

- 1. Steel stud (16 GA typical)
- 2. Perimeter anchor
- 3. Alpha H wall bracket
- 4. st/st self-drilling screw  $\frac{3}{16} \times \frac{3}{4}$ "
- 5. st/st self-drilling screw  $\frac{1}{4} \times 1$ "
- 6. Horizontal L-profile
- 7. Vertical Z-profile
- 8. Blind rivet
- 9. Insulation

- 11. Panel
- 12. A/V barrier
- 13. Exterior wall
- 14. Outer corner closure
- 15. Inner corner closure
- 16. Jamb closure
- 17. Vertical L-profile
- 18. Coping
- 19. Perforated window head closure
- 20. Window sill

- 21. Perforated base closure

D - System depth

t - Panel thickness

\* Ventilation will vary based on insulation depth.

\*\* Minimum ventilation requirement should be qualified by panel manufacturer.

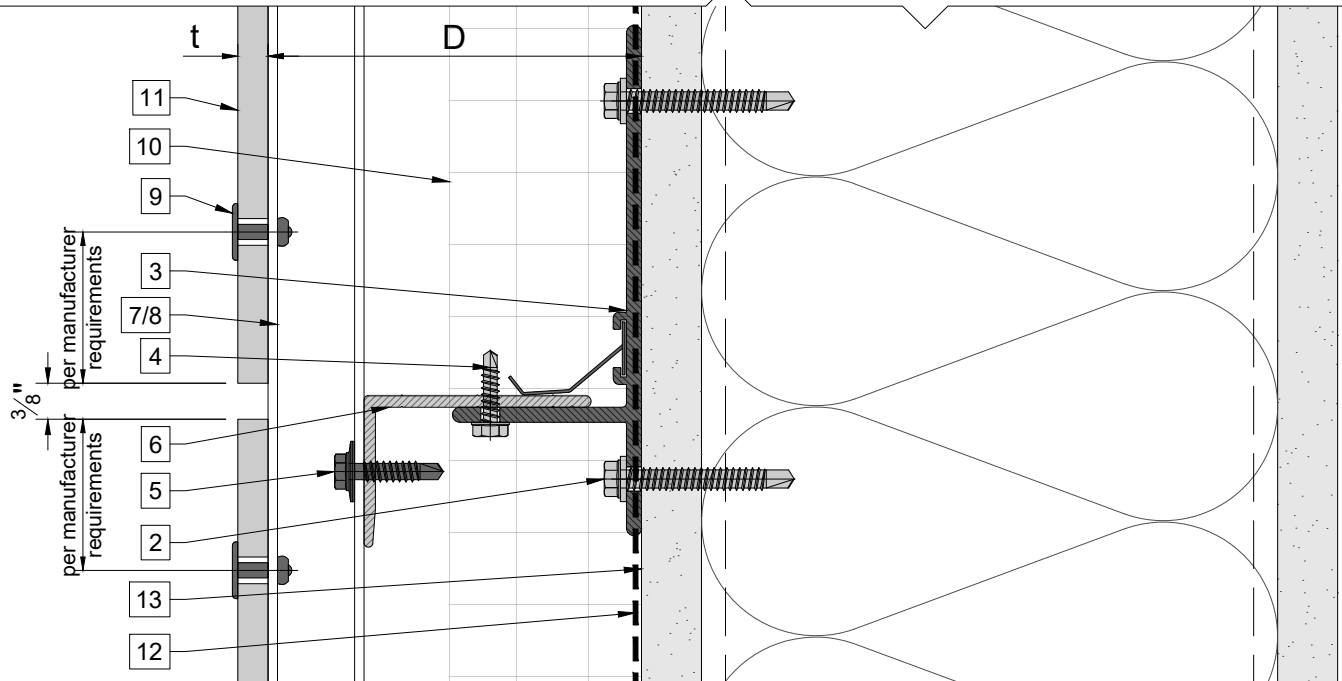
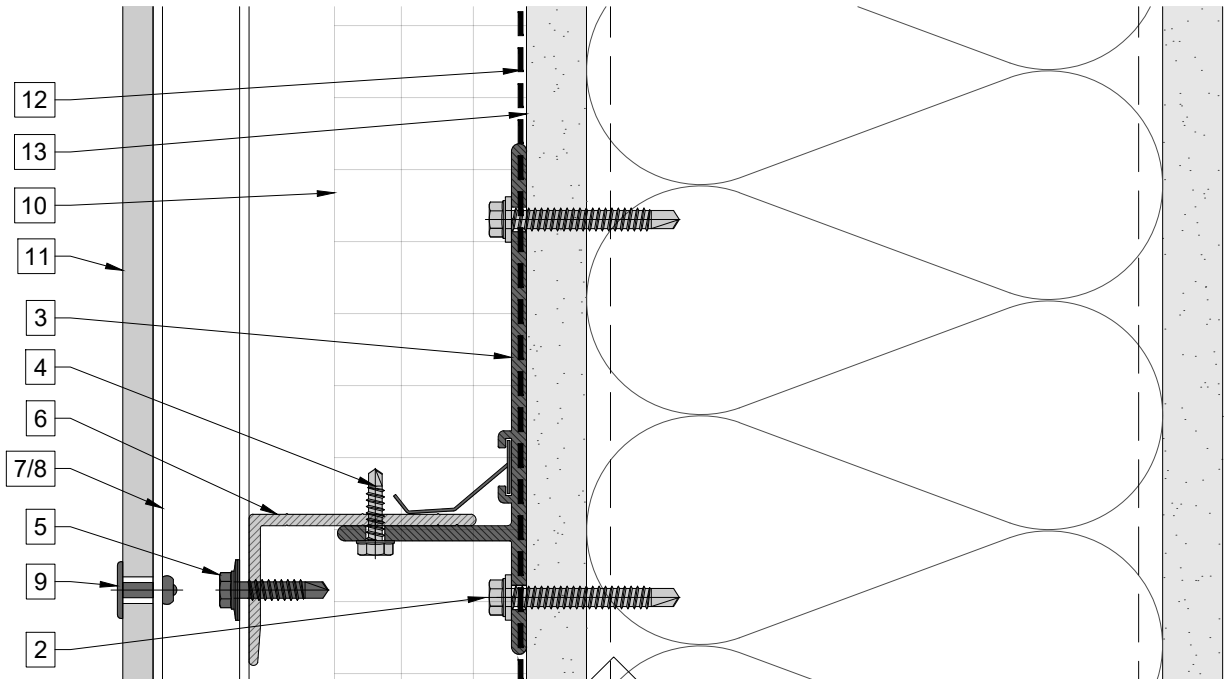

Legend

- 1. Steel stud (16 GA typical)
- 2. Perimeter anchor
- 3. Alpha H wall bracket
- 4. st/st self-drilling screw  $\frac{3}{16} \times \frac{3}{4}$ "
- 5. st/st self-drilling screw  $\frac{1}{4} \times 1$ "
- 6. Horizontal L-profile
- 7. Vertical Z-profile
- 8. Vertical Hat-profile
- 9. Blind rivet
- 10. Insulation

- 11. Panel
- 12. A/V barrier
- 13. Exterior wall
- 14. Outer corner closure
- 15. Inner corner closure
- 16. Jamb closure
- 17. Vertical L-profile
- 18. Coping
- 19. Perforated window head closure
- 20. Window sill

- 21. Perforated base closure

D - System depth  
t - Panel thickness

\* Ventilation will vary based on insulation depth.

\*\* Minimum ventilation requirement should be qualified by panel manufacturer.

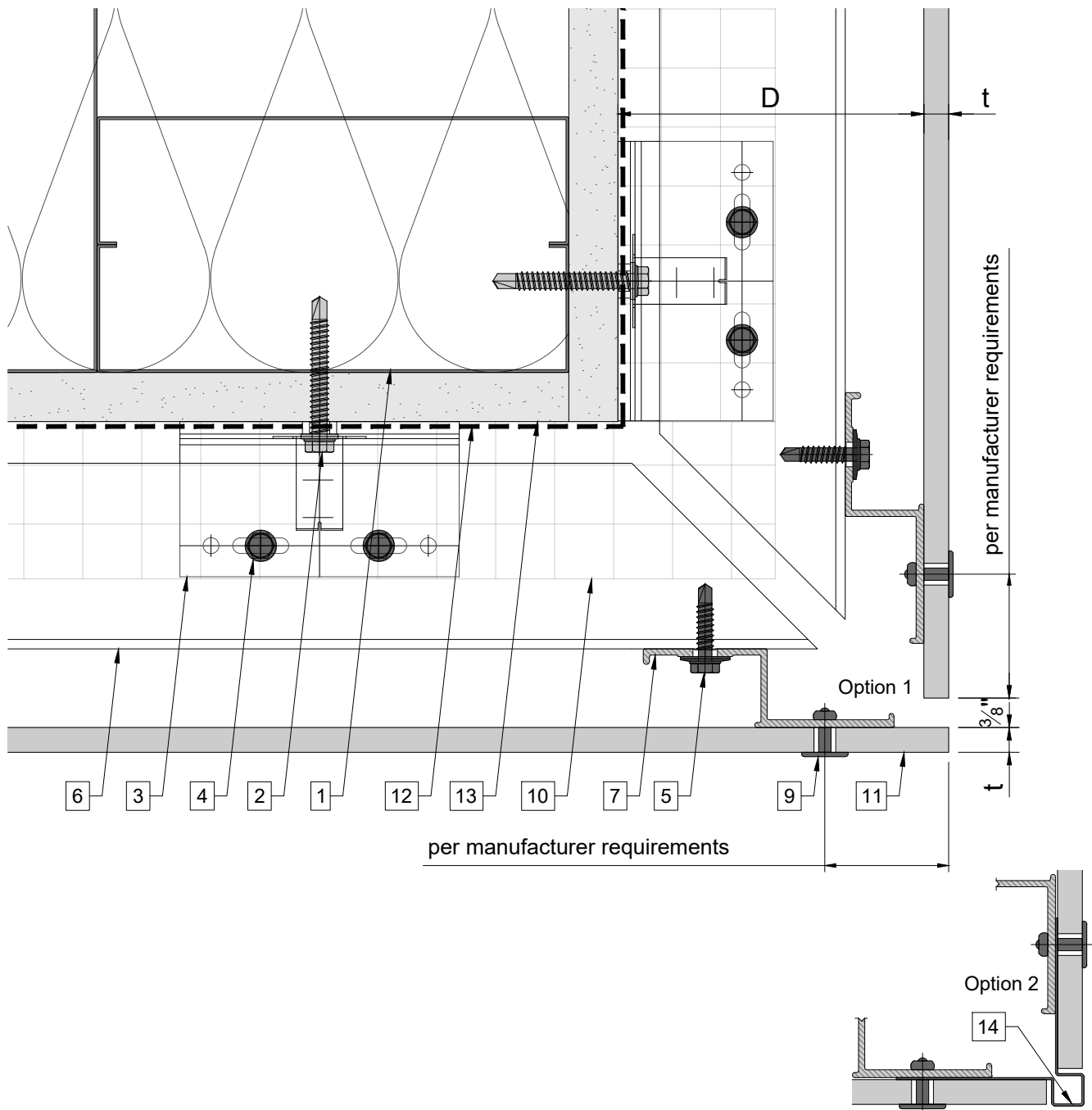

**Legend**

- 1. Steel stud (16 GA typical)
- 2. Perimeter anchor
- 3. Alpha H wall bracket
- 4. st/st self-drilling screw  $\frac{3}{16} \times \frac{3}{4}$ "
- 5. st/st self-drilling screw  $\frac{1}{4} \times 1$ "
- 6. Horizontal L-profile
- 7. Vertical Z-profile
- 8. Vertical Hat-profile
- 9. Blind rivet
- 10. Insulation

- 11. Panel
- 12. A/V barrier
- 13. Exterior wall
- 14. Outer corner closure
- 15. Inner corner closure
- 16. Jamb closure
- 17. Vertical L-profile
- 18. Coping
- 19. Perforated window head closure
- 20. Window sill

- 21. Perforated base closure

D - System depth  
t - Panel thickness

\* Ventilation will vary based on insulation depth.  
\*\* Minimum ventilation requirement should be qualified by panel manufacturer.

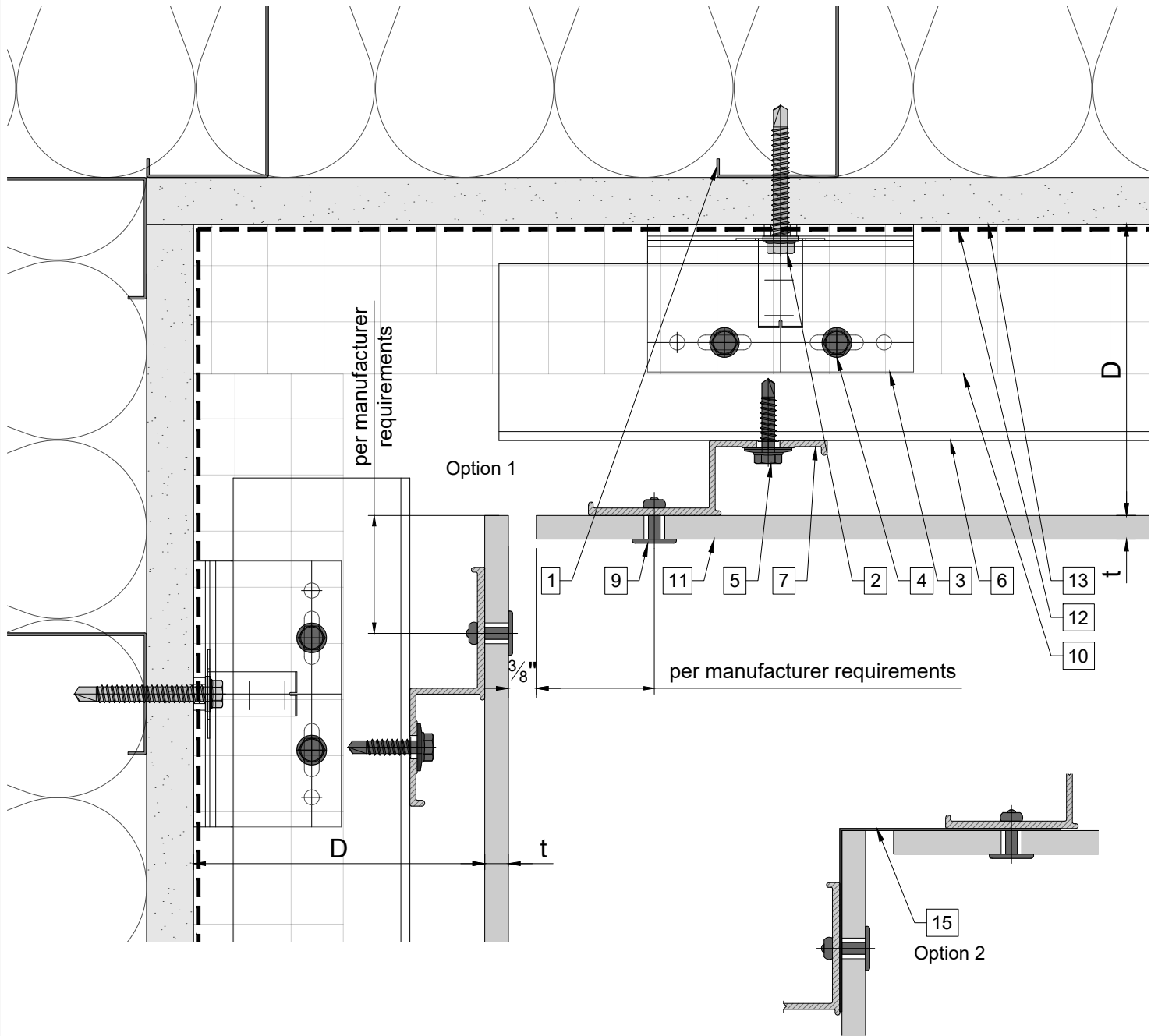

**Legend**

- 1. Steel stud (16 GA typical)
- 2. Perimeter anchor
- 3. Alpha H wall bracket
- 4. st/st self-drilling screw  $\frac{3}{16} \times \frac{3}{4}$ "
- 5. st/st self-drilling screw  $\frac{1}{4} \times 1$ "
- 6. Horizontal L-profile
- 7. Vertical Z-profile
- 8. Vertical Hat-profile
- 9. Blind rivet
- 10. Insulation

- 11. Panel
- 12. A/V barrier
- 13. Exterior wall
- 14. Outer corner closure
- 15. Inner corner closure
- 16. Jamb closure
- 17. Vertical L-profile
- 18. Coping
- 19. Perforated window head closure
- 20. Window sill

- 21. Perforated base closure

D - System depth

t - Panel thickness

\* Ventilation will vary based on insulation depth.

\*\* Minimum ventilation requirement should be qualified by panel manufacturer.

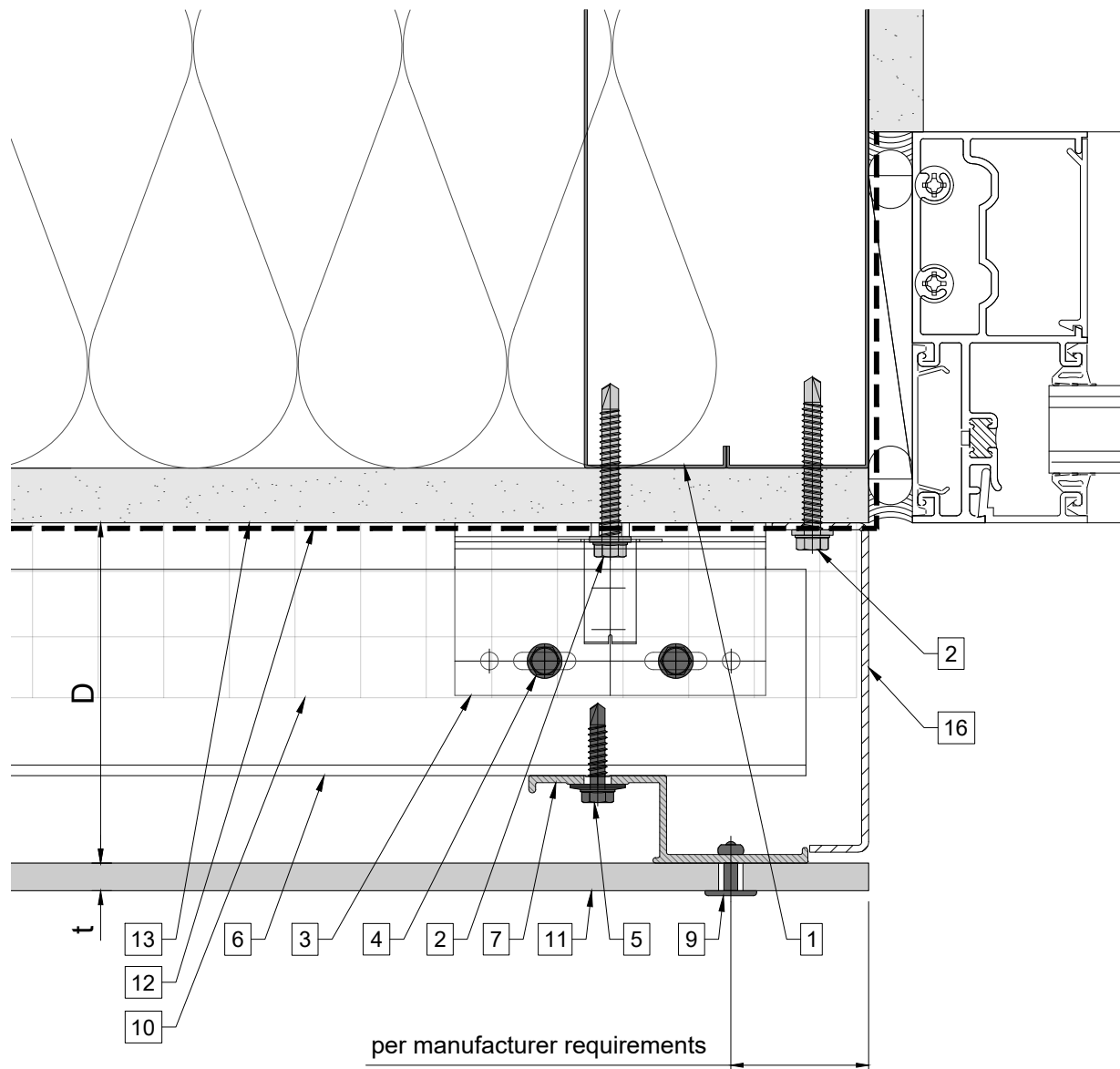

**Legend**

- 1. Steel stud (16 GA typical)
- 2. Perimeter anchor
- 3. Alpha H wall bracket
- 4. st/st self-drilling screw  $\frac{3}{16} \times \frac{3}{4}$ "
- 5. st/st self-drilling screw  $\frac{1}{4} \times 1$ "
- 6. Horizontal L-profile
- 7. Vertical Z-profile
- 8. Blind rivet
- 9. Insulation

- 11. Panel
- 12. A/V barrier
- 13. Exterior wall
- 14. Outer corner closure
- 15. Inner corner closure
- 16. Jamb closure
- 17. Vertical L-profile
- 18. Coping
- 19. Perforated window head closure
- 20. Window sill

- 21. Perforated base closure

D - System depth

t - Panel thickness

\* Ventilation will vary based on insulation depth.

\*\* Minimum ventilation requirement should be qualified by panel manufacturer.





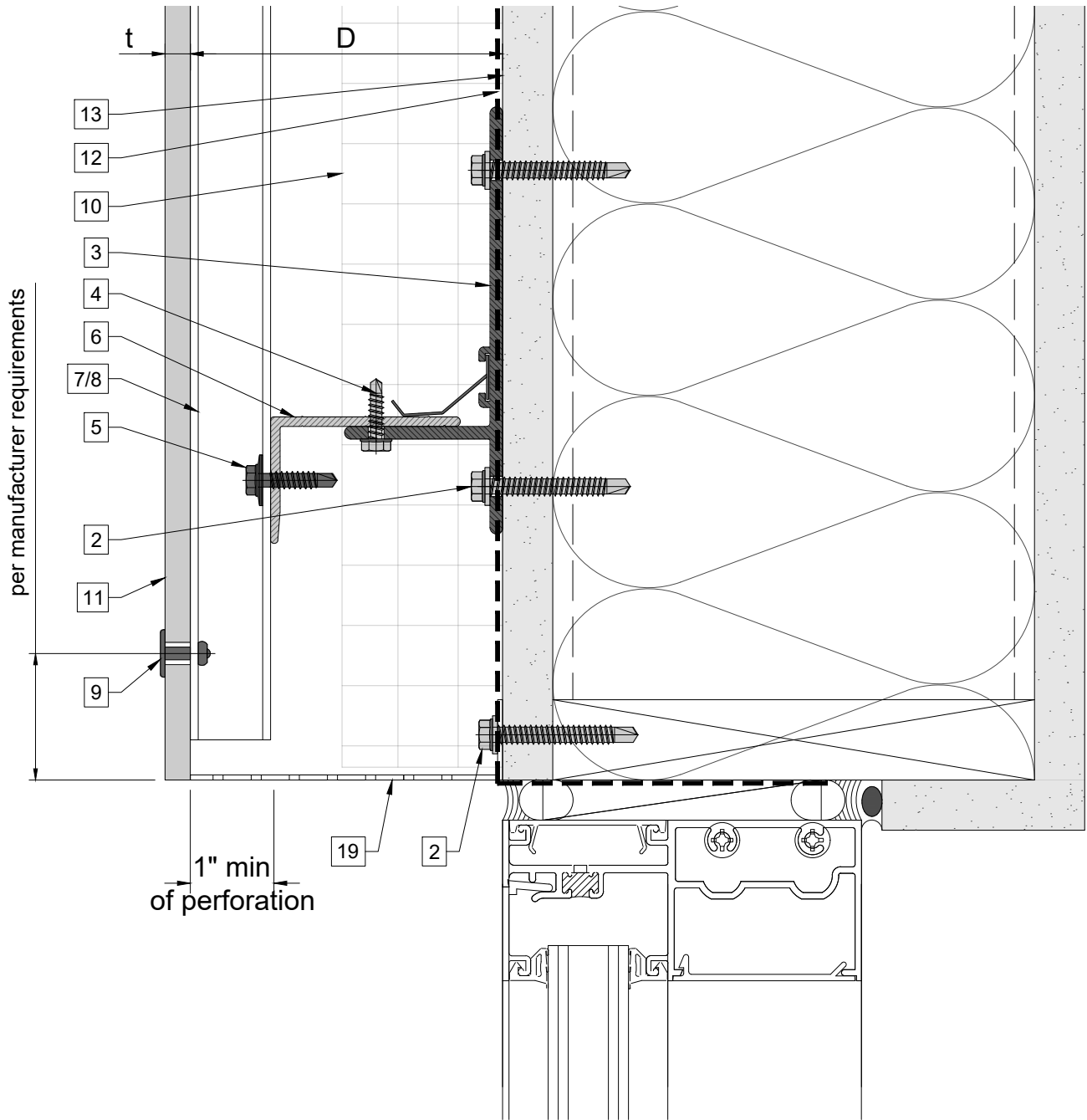

**Legend**

- 1. Steel stud (16 GA typical)
- 2. Perimeter anchor
- 3. Alpha H wall bracket
- 4. st/st self-drilling screw  $\frac{3}{16} \times \frac{3}{4}$ "
- 5. st/st self-drilling screw  $\frac{1}{4} \times 1$ "
- 6. Horizontal L-profile
- 7. Vertical Z-profile
- 8. Vertical Hat-profile
- 9. Blind rivet
- 10. Insulation

- 11. Panel
- 12. A/V barrier
- 13. Exterior wall
- 14. Outer corner closure
- 15. Inner corner closure
- 16. Jamb closure
- 17. Vertical L-profile
- 18. Coping
- 19. Perforated window head closure
- 20. Window sill

- 21. Perforated base closure

D - System depth  
t - Panel thickness

\* Ventilation will vary based on insulation depth.

\*\* Minimum ventilation requirement should be qualified by panel manufacturer.

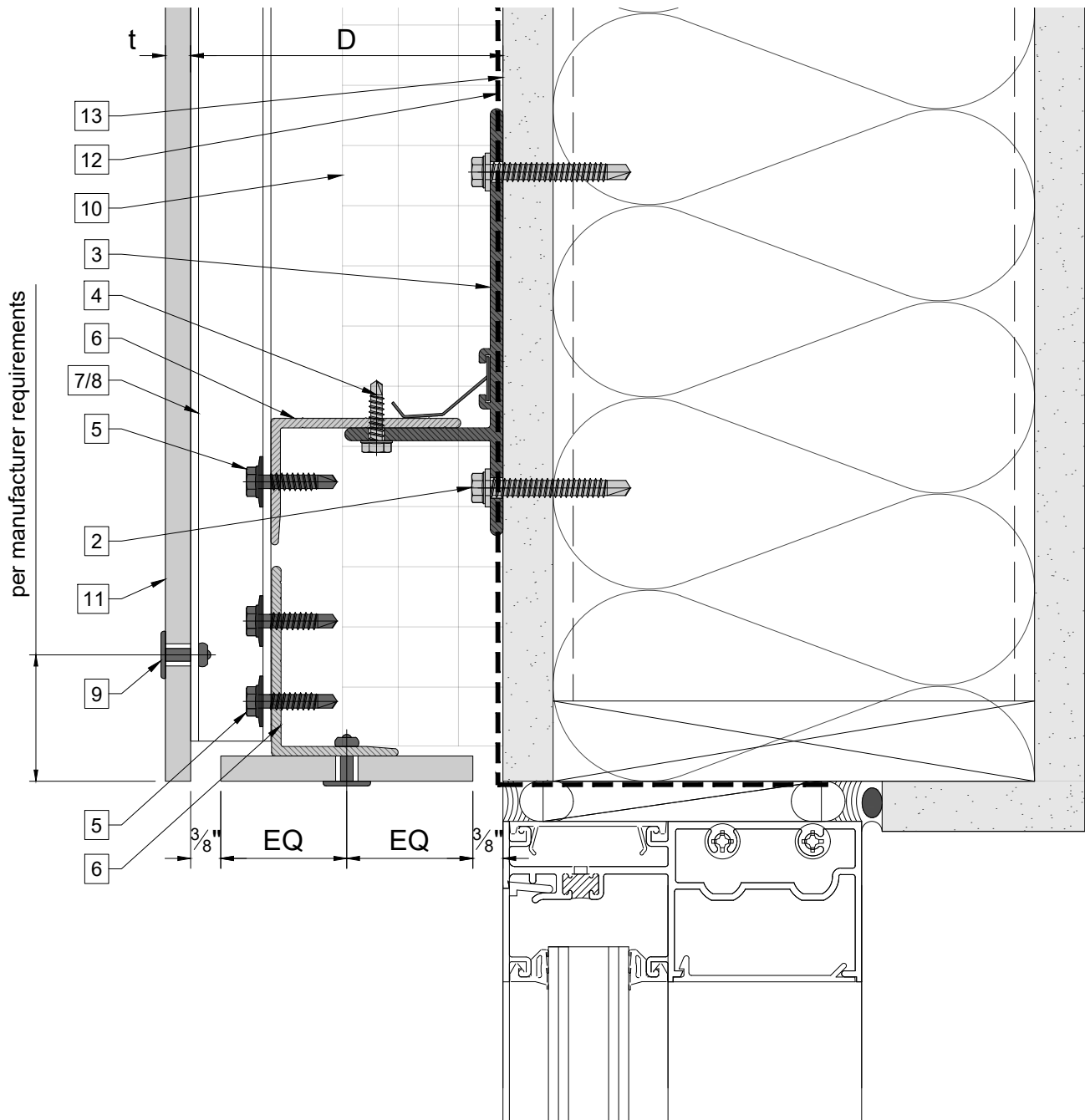

**Legend**

- 1. Steel stud (16 GA typical)
- 2. Perimeter anchor
- 3. Alpha H wall bracket
- 4. st/st self-drilling screw  $\frac{3}{16} \times \frac{3}{4}$ "
- 5. st/st self-drilling screw  $\frac{1}{4} \times 1$ "
- 6. Horizontal L-profile
- 7. Vertical Z-profile
- 8. Vertical Hat-profile
- 9. Blind rivet
- 10. Insulation

- 11. Panel
- 12. A/V barrier
- 13. Exterior wall
- 14. Outer corner closure
- 15. Inner corner closure
- 16. Jamb closure
- 17. Vertical L-profile
- 18. Coping
- 19. Perforated window head closure
- 20. Window sill

- 21. Perforated base closure

D - System depth  
t - Panel thickness

\* Ventilation will vary based on insulation depth.

\*\* Minimum ventilation requirement should be qualified by panel manufacturer.

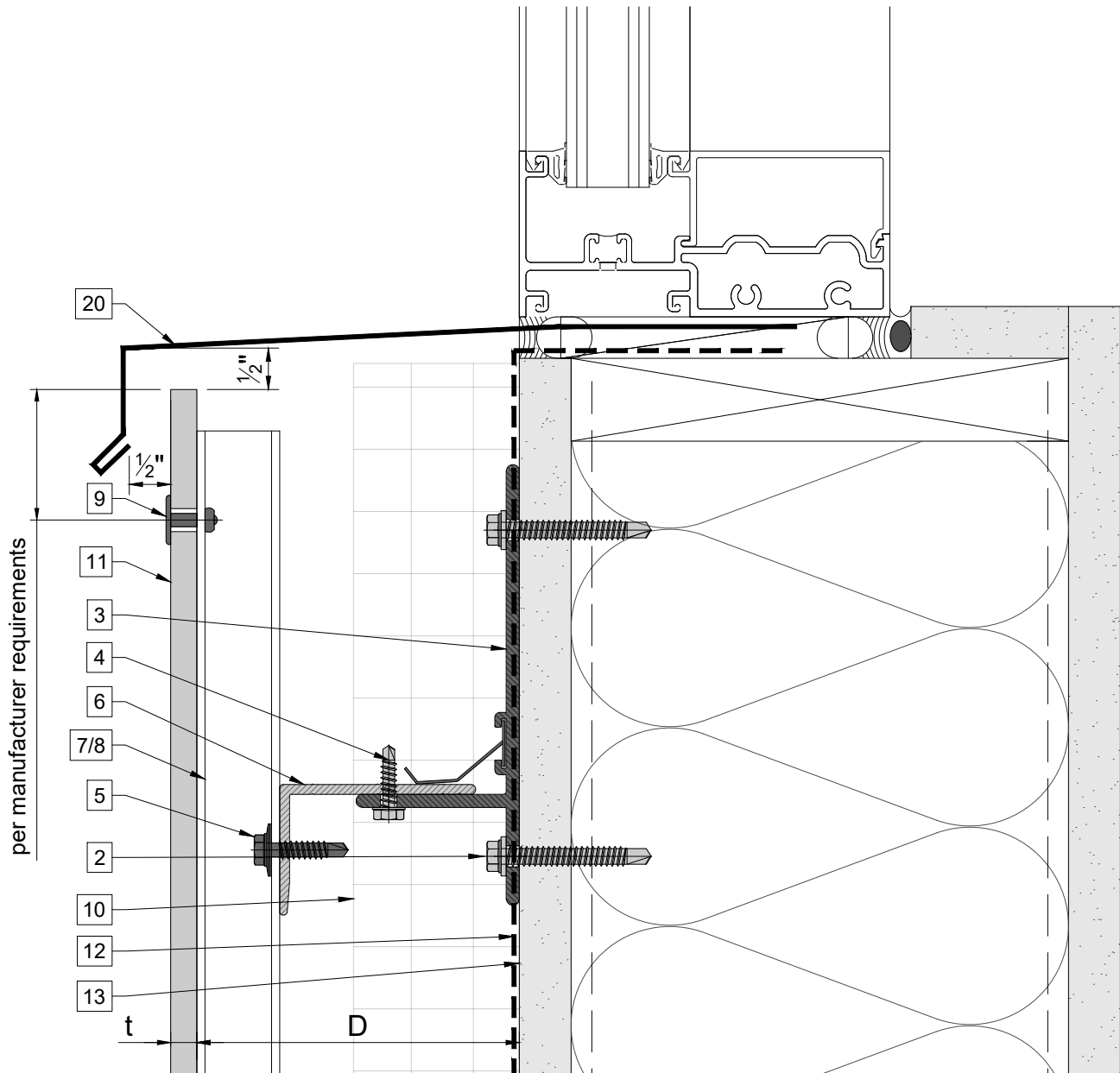

**Legend**

- 1. Steel stud (16 GA typical)
- 2. Perimeter anchor
- 3. Alpha H wall bracket
- 4. st/st self-drilling screw  $\frac{3}{16} \times \frac{3}{4}$ "
- 5. st/st self-drilling screw  $\frac{1}{4} \times 1$ "
- 6. Horizontal L-profile
- 7. Vertical Z-profile
- 8. Vertical Hat-profile
- 9. Blind rivet
- 10. Insulation

- 11. Panel
- 12. A/V barrier
- 13. Exterior wall
- 14. Outer corner closure
- 15. Inner corner closure
- 16. Jamb closure
- 17. Vertical L-profile
- 18. Coping
- 19. Perforated window head closure
- 20. Window sill

- 21. Perforated base closure

D - System depth

t - Panel thickness

\* Ventilation will vary based on insulation depth.

\*\* Minimum ventilation requirement should be qualified by panel manufacturer.

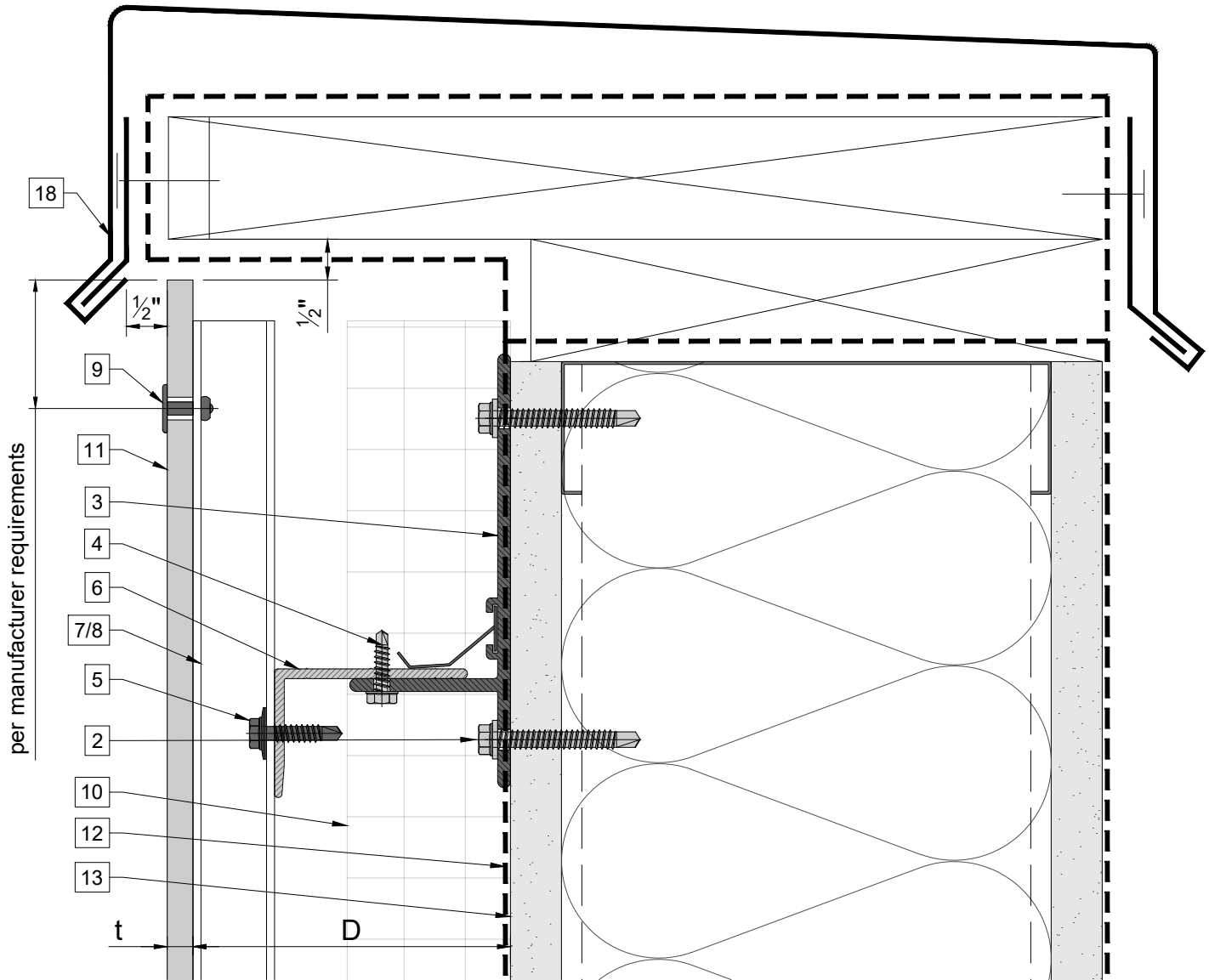

**Legend**

1. Steel stud (16 GA typical)
2. Perimeter anchor
3. Alpha H wall bracket
4. st/st self-drilling screw  $\frac{3}{16} \times \frac{3}{4}$ "
5. st/st self-drilling screw  $\frac{1}{4} \times 1$ "
6. Horizontal L-profile
7. Vertical Z-profile
8. Blind Hat-profile
9. Blind rivet
10. Insulation

11. Panel
12. A/V barrier
13. Exterior wall
14. Outer corner closure
15. Inner corner closure
16. Jamb closure
17. Vertical L-profile
18. Coping
19. Perforated window head closure
20. Window sill

21. Perforated base closure

D - System depth

t - Panel thickness

\* Ventilation will vary based on insulation depth.

\*\* Minimum ventilation requirement should be qualified by panel manufacturer.

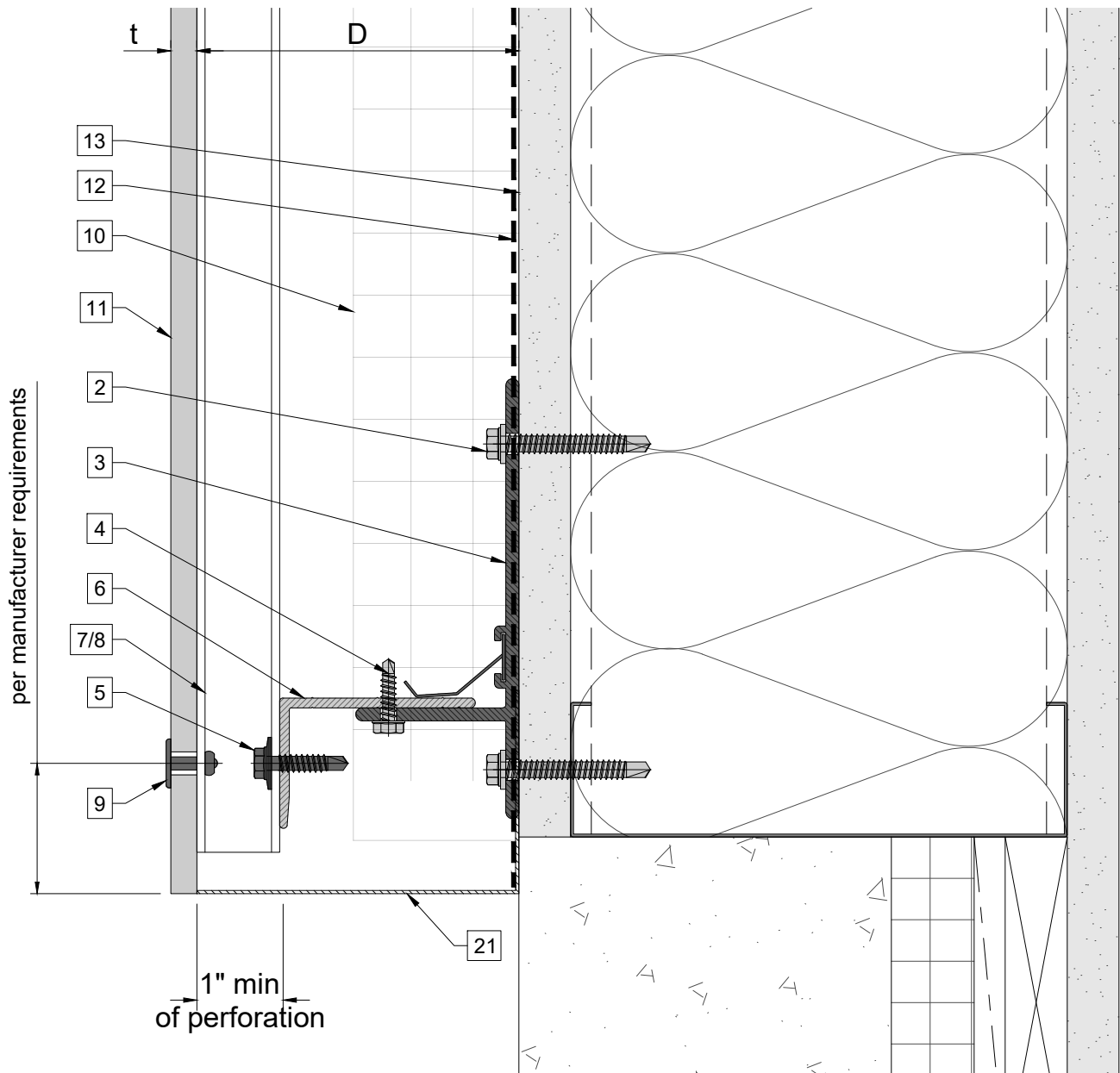

Legend

- 1. Steel stud (16 GA typical)
- 2. Perimeter anchor
- 3. Alpha H wall bracket
- 4. st/st self-drilling screw  $\frac{3}{16} \times \frac{3}{4}$ "
- 5. st/st self-drilling screw  $\frac{1}{4} \times 1$ "
- 6. Horizontal L-profile
- 7. Vertical Z-profile
- 8. Vertical Hat-profile
- 9. Blind rivet
- 10. Insulation

- 11. Panel
- 12. A/V barrier
- 13. Exterior wall
- 14. Outer corner closure
- 15. Inner corner closure
- 16. Jamb closure
- 17. Vertical L-profile
- 18. Coping
- 19. Perforated window head closure
- 20. Window sill

- 21. Perforated base closure

D - System depth  
t - Panel thickness

\* Ventilation will vary based on insulation depth.

\*\* Minimum ventilation requirement should be qualified by panel manufacturer.