

Baguettes

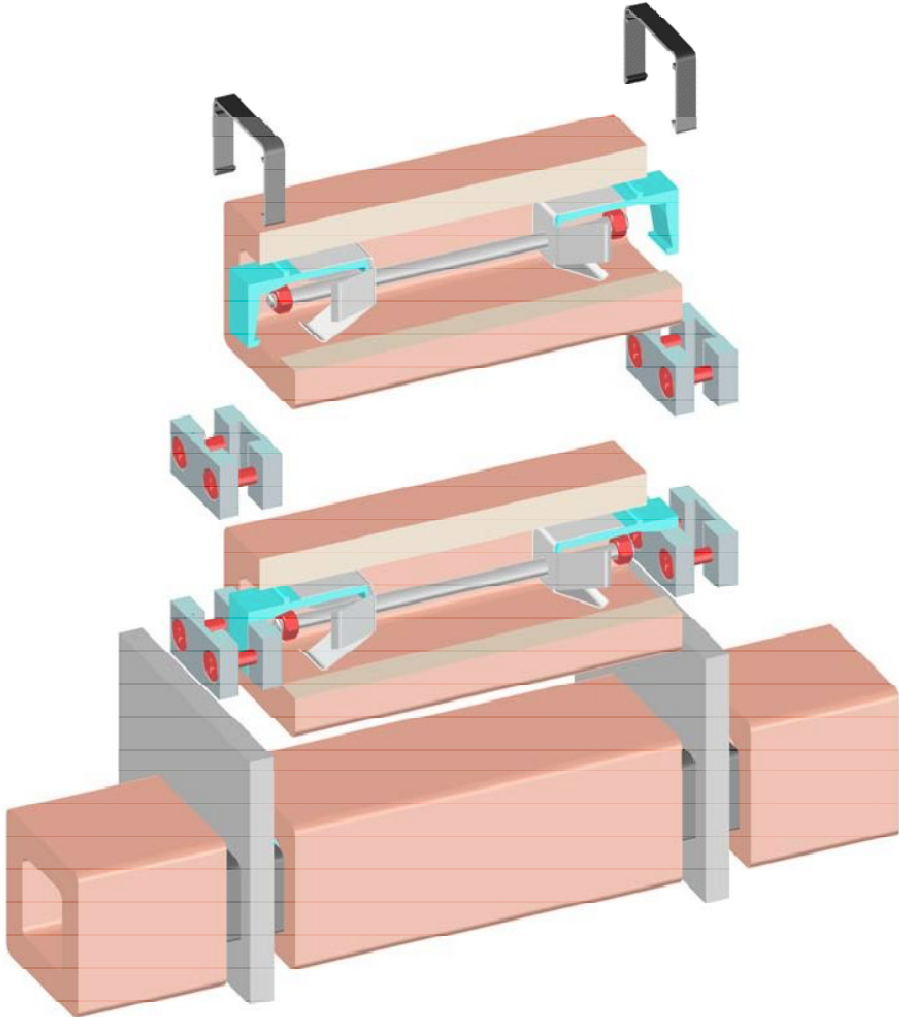

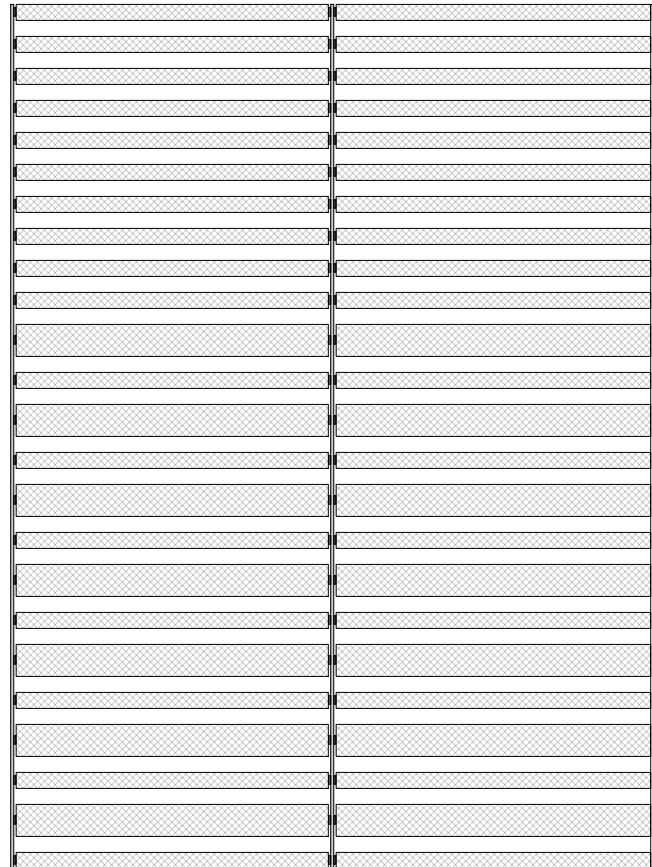

2" x 2" Baguette section
pg.03

2" x 4" Baguette section
pg.04

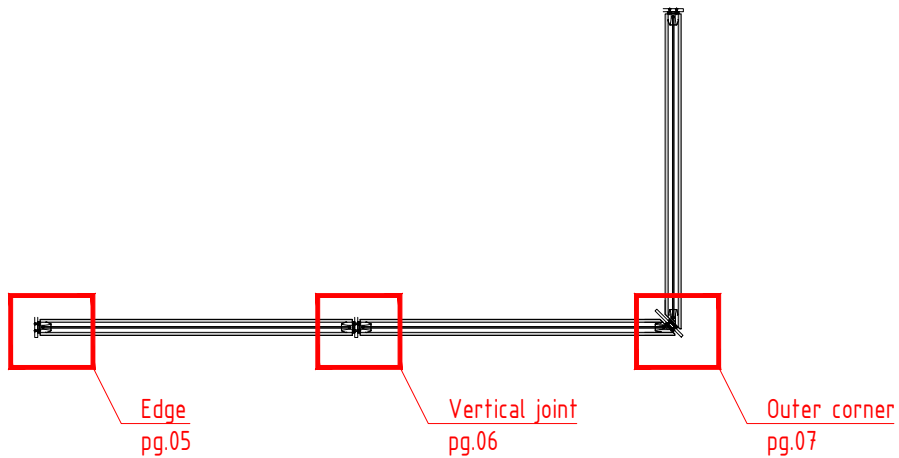

Edge
pg.05

Vertical joint
pg.06

Outer corner
pg.07

2"x2" Baguette section

Condition 1

Condition 2

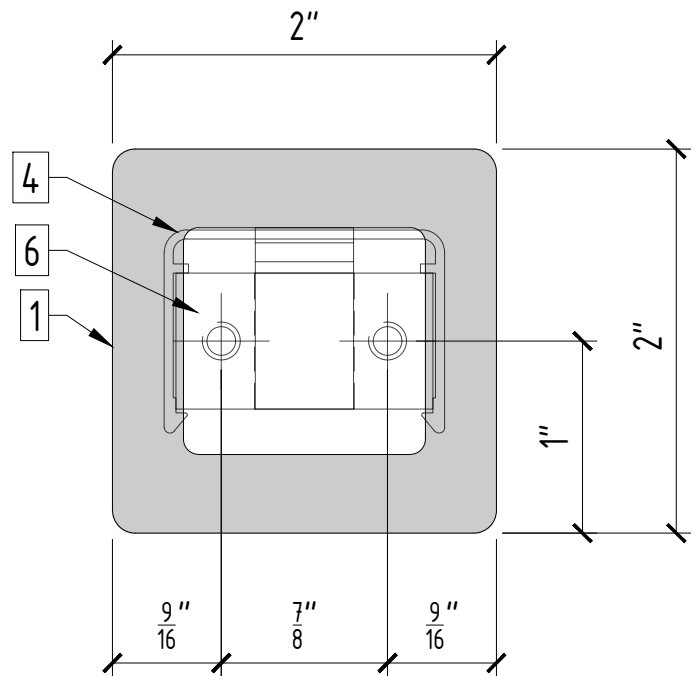
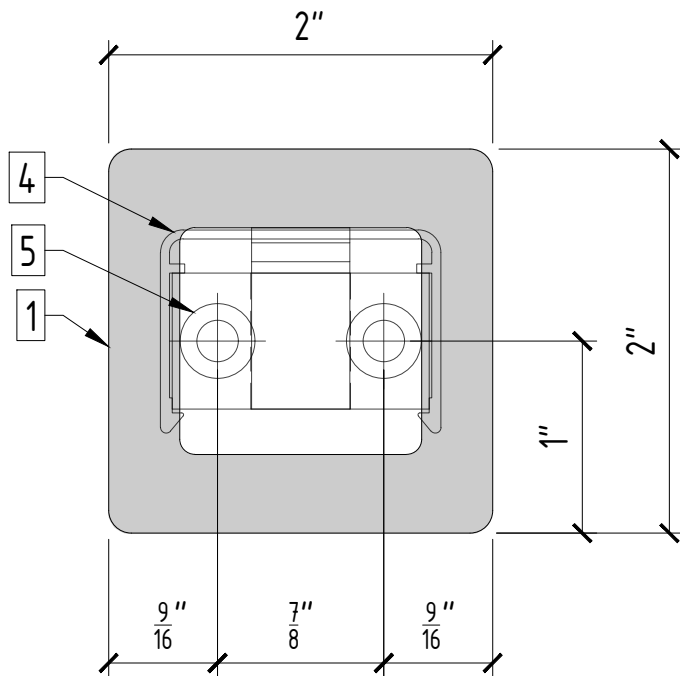

1	2"x2" Baguette	6	Fixing bracket, mill (B-03-122)	11	Baguette holder left, mill (B-03-213)
2	2"x4" Baguette	7	Countersunk screw M5x22	12	Threaded rod M5
3	Fin-outrigger 3/8"	8	Countersunk screw M5x16	13	Washer M5
4	Cover cap, black anodized (F-03-131-B)	9	Baguette holder, mill (B-03-210)		
5	Fixing bracket, mill (B-03-121)	10	Baguette holder right, mill (B-03-215)		

2"x4" Baguette section

Condition 1

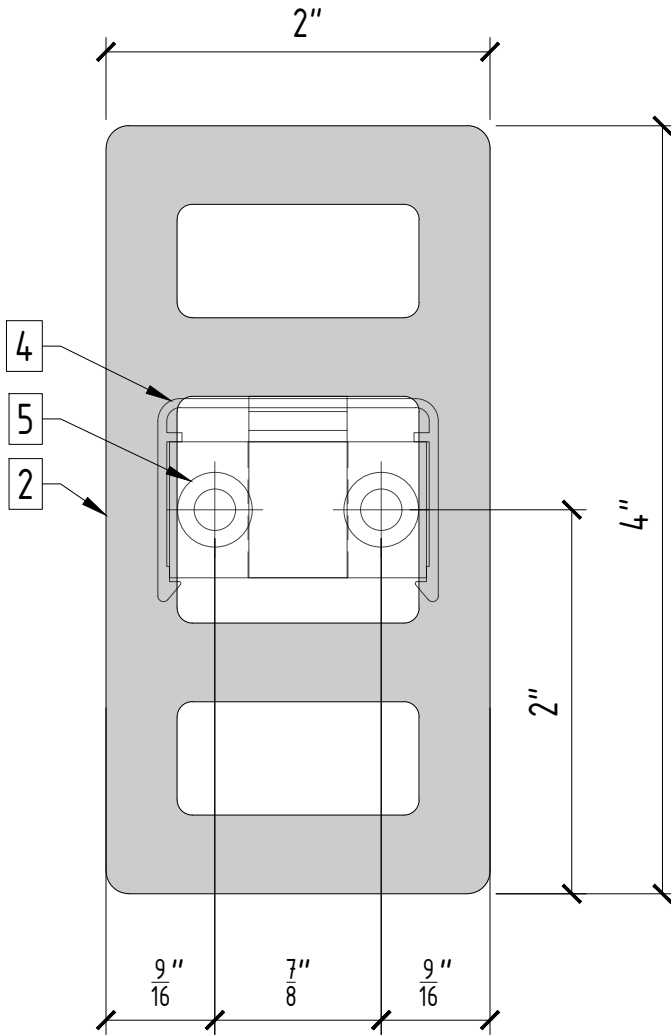

Condition 2

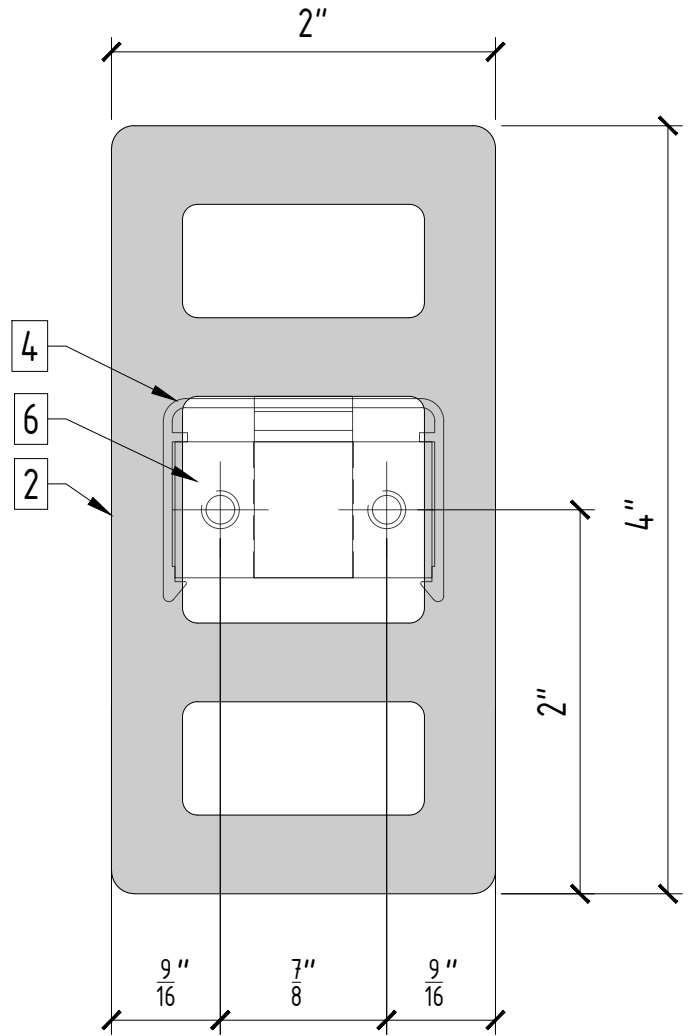

1	2"x2" Baguette	6	Fixing bracket, mill (B-03-122)	11	Baguette holder left, mill (B-03-213)
2	2"x4" Baguette	7	Countersunk screw M5x22	12	Threaded rod M5
3	Fin-outrigger 3/8"	8	Countersunk screw M5x16	13	Washer M5
4	Cover cap, black anodized (F-03-131-B)	9	Baguette holder, mill (B-03-210)		
5	Fixing bracket, mill (B-03-121)	10	Baguette holder right, mill (B-03-215)		

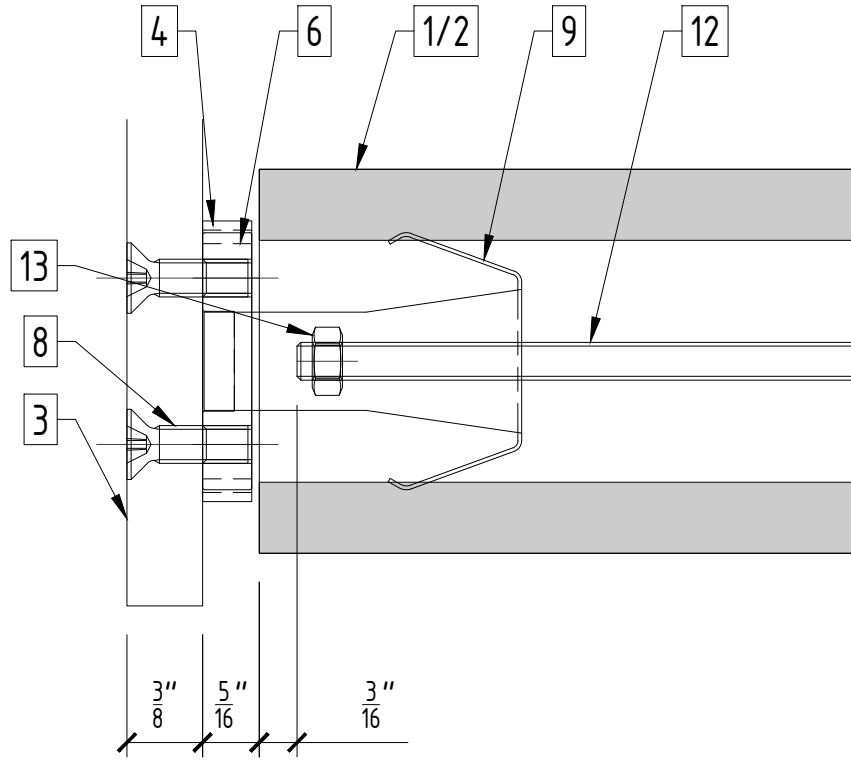

1	2"x2" Baguette	6	Fixing bracket, mill (B-03-122)	11	Baguette holder left, mill (B-03-213)
2	2"x4" Baguette	7	Countersunk screw M5x22	12	Threaded rod M5
3	Fin-outtrigger 3/8"	8	Countersunk screw M5x16	13	Washer M5
4	Cover cap, black anodized (F-03-131-B)	9	Baguette holder, mill (B-03-210)		
5	Fixing bracket, mill (B-03-121)	10	Baguette holder right, mill (B-03-215)		

Vertical joint

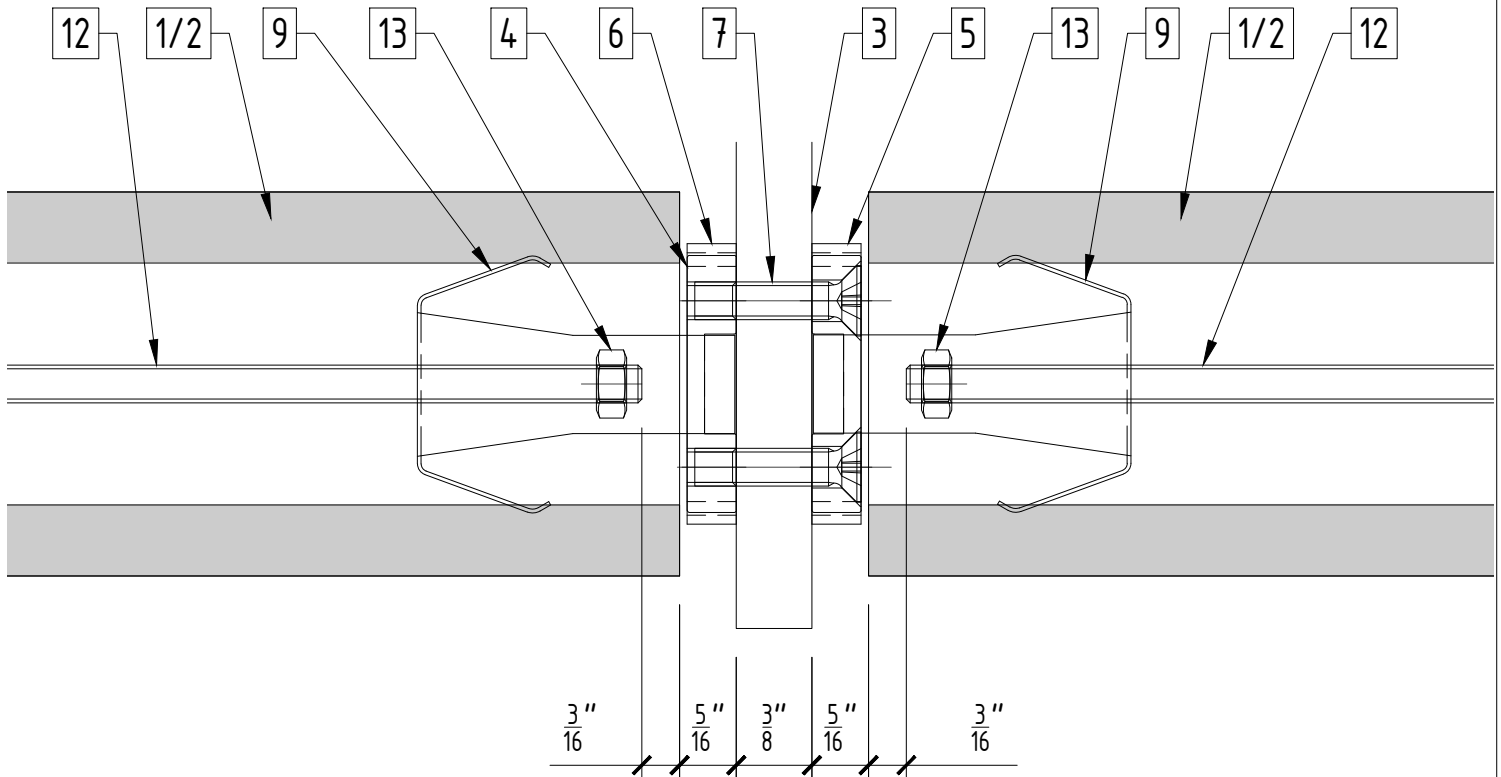

1	2"x2" Baguette	6	Fixing bracket, mill (B-03-122)	11	Baguette holder left, mill (B-03-213)
2	2"x4" Baguette	7	Countersunk screw M5x22	12	Threaded rod M5
3	Fin-outrigger 3/8"	8	Countersunk screw M5x16	13	Washer M5
4	Cover cap, black anodized (F-03-131-B)	9	Baguette holder, mill (B-03-210)		
5	Fixing bracket, mill (B-03-121)	10	Baguette holder right, mill (B-03-215)		

Outer corner

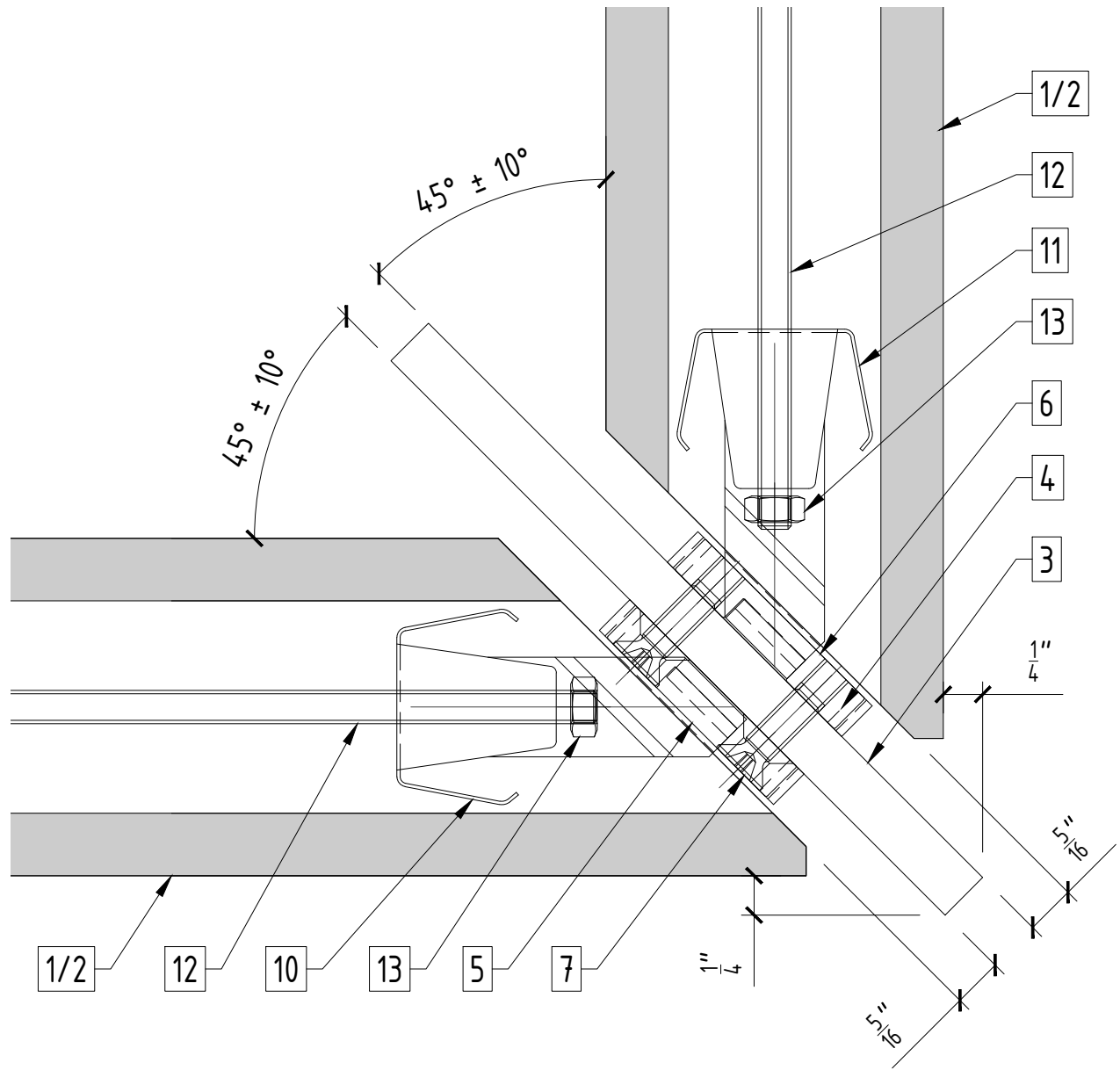

1	2"x2" Baguette	6	Fixing bracket, mill (B-03-122)	11	Baguette holder left, mill (B-03-213)
2	2"x4" Baguette	7	Countersunk screw M5x22	12	Threaded rod M5
3	Fin-outrigger 3/8"	8	Countersunk screw M5x16	13	Washer M5
4	Cover cap, black anodized (F-03-131-B)	9	Baguette holder, mill (B-03-210)		
5	Fixing bracket, mill (B-03-121)	10	Baguette holder right, mill (B-03-215)		